

XAG Agricultural Remote Controller 3 Pro User Manual

Version 1.0 **EN**

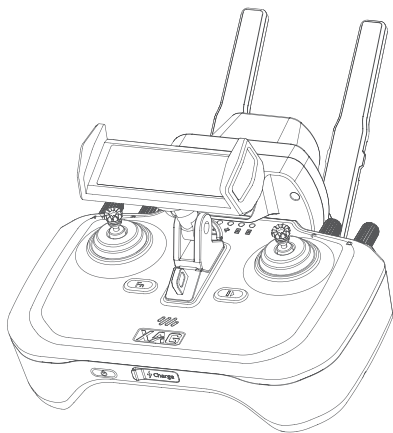

To User

Dear user, thank you for choosing XAG's products.

For safety purposes and better user experience, it is highly recommended that you read this manual carefully and strictly follow the instructions hereof.

Contact Us

Manufacturer: Guangzhou Xaircraft Technology CO., LTD.

Add: XSpace, No.115, Gaopu Road, Guangzhou, Guangdong Province, China

Technical Support Team: support@xa.com

Introduction

The XAG Agricultural Remote Controller 3 Pro(ARC3 Pro) is a screen-free two-handed remote controller for agricultural use. High-precision mapping is available when it is equipped with the special RTK positioning module. Its four knobs and many buttons, specially designed for the XAG agricultural drones, plus WiFi+4G networking and dual SIM dual standby make it possible to operate the farm equipment easily without an app, thus enhancing the efficiency of manual remote operation.

List of Items

Please see that all of the following items are present when unpacking the box. Should there be any item missing, please contact your seller.

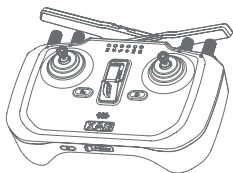

ARC3 Pro
×1



RTK Module
×1



Charger
×1



Neck Strap
×1

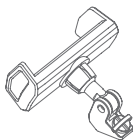

Phone Holder
×1

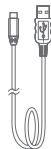

USB-A To Type-C Cable
×1

Overview

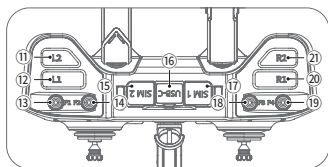
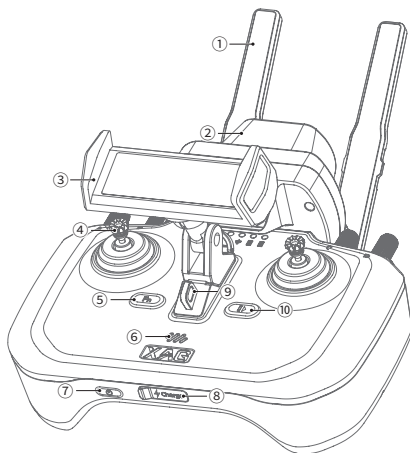

1. Antenna

2. RTK Module

3. Phone Holder

4. Joystick

5. Fn Button

6. Buzzer

7. Power Button

8. Charging Port

9. Neck Strap Ring

10. Stop Button

11. L2 Button

12. L1 Button

13. F1 Knob

14. F2 Knob

15. SIM2 Card Slot

16. USB-C Port

17. SIM1 Card Slot

18. F3 Knob

19. F4 Knob

20. R1 Button

21. R2 Button

About Buttons

Button	Operation	Description
Stop Button	Short Press	Joystick Self-calibration Mode: next
		Hover the aircraft; Remote controller goes into manual operation mode
	Long Press	Keep the aircraft on "Auxiliary Mode" or "Autonomous Mode"
Fn Button	Long Press	Enter/exit Mapping Mode; In Mapping Mode, short press L1 to mark the current position, and short press L2 to undo the previous mark. In Mapping Mode, remote controller can only be used for mapping rather than piloting the aircraft.
		Long Press Fn Button+Stop Button
	Fn Button+push both joysticks to the bottom left limit	Enable Joystick Self-calibration Mode
F1 Knob	Twiddle	Auxiliary Mode: adjust route spacing
	Short Press	Enable obstacle avoidance
	Long Press	Disable obstacle avoidance
F2 Knob	Twiddle	Auxiliary Mode: adjust route direction
	Short Press	Disable Terrain-following Mode
	Long Press	Enable Terrain-following Mode
F3 Knob	Twiddle	Adjust droplet size while the aircraft is spraying
	Short Press	Toggle one-side/two-side spraying
	Long Press	Toggle variable-rate/constant-rate spraying
F4 Knob	Twiddle	Adjust the flow rate when the aircraft is spraying
	Short Press	Stop spraying
	Long Press	Start spraying

L1 Button	Short Press	Mapping Mode: Fly to Mark, Mark by Remote Controller Auxiliary Mode: proceed with "Auxiliary Mode" ^[1]
	Long Press	Mapping Mode: form a close shape Auxiliary Mode: Enable "Auxiliary Mode"; Long press again to set the current height as the altitude for the auxiliary mode.
L2 Button	Short Press	Mapping Mode: undo the mark in "Fly to Mark", undo the mark in "Mark by Remote Controller" Auxiliary Mode: turn around to the left row
	Long Press	Auxiliary Mode: move to the left row
R1 Button	Short Press	Toggle forward/downward PSL camera
R2 Button	Short Press	Auxiliary Mode: turn around to the right row
	Long Press	Auxiliary Mode: move to the right row

[1]: In Auxiliary Mode, you can adjust the height of the aircraft by moving the "throttle" and the aircraft will automatically return to the default height after releasing the "throttle".

Status Indicators

When the remote controller is off, short the press power button to check the battery level.

Indicator	Description
One Green Light On	Battery level: 1%-20%, please charge
Two Green Lights On	Battery level: 21%-35%
Three Green Lights On	Battery level: 36%-50%
Four Green Lights On	Battery level: 51%-65%
Five Green Lights On	Battery level: 66%-80%
Six Green Lights On	Battery level: 81%-100%

When the remote controller is on, the indicators will tell you the status of the remote controller and the aircraft.

Battery Indicator 	Description
Solid Green	Battery level: 51%-100%
Solid Yellow	Battery level: 21%-50%
Solid Red	Battery level: 1%-20%

Battery Indicator 	Description
Single Flashing Green	Fast charging
Off	Off

Mobile Network Indicator 	Description
Solid Green	LAN communication normal
Single Flashing Green	LAN/WAN communication
Solid Yellow	LNT mode communication normal
Solid Red	Communication error
Off	SIM card not detected

Wireless Communication Indicator 	Description
Solid Green	Communication with aircraft normal
Single Flashing Green	Initializing remote controller communication
Single Flashing Yellow	Pairing network
Off	No aircraft connected

External Device Indicator 	Description
Solid Green	RTK positioning, ready for mapping
Double Flashing Green	Single positioning, ready for mapping
Single Flashing Green	Positioning, cannot map
Solid Yellow	RTK module sleeping
Solid Red	RTK module communication error
Off	RTK module not detected

Function Indicator A 	Description
Solid Green	Manual control
Single Flashing Green	Auxiliary mode
Solid Yellow	Manual flight mapping
Single Flashing Yellow	Aircraft returning or making an emergency landing
Solid Red	Joystick error, please calibrate
Off	Fully autonomous mode

Function Indicator B 	Description
Solid Green	Manual spray - On
Off	Manual spray - Off
Single Flashing Yellow	Running low on pesticide

Buzzer

When the buzzer is on, the beep code will tell you the status of the remote controller and the aircraft.

Buzzer	Description
Long Beep	Remote controller: power on/off, add a device
One Short Beep	Short press any button or twiddle a knob
Two Short Beeps	Long press any button, or link, calibrate or charge the remote controller
Three Short Beeps (consecutive)	Warning of the payload system or smart system of the aircraft
Three Long Beeps (consecutive)	Low battery warning or system error of the remote controller

Joystick Mode

The Joystick Mode is divided into Japanese Hand, American Hand and Chinese Hand. The default mode is American Hand (Mode 2).

Japanese Hand (Mode 1)

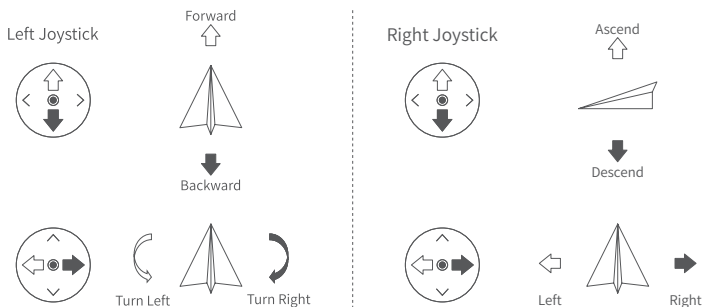

American Hand (Mode 2)

Left Joystick



Ascend



Descend



Turn Left

Turn Right

Right Joystick



Forward



Backward



Left

Right

Chinese Hand (Mode 3)

Left Joystick



Forward



Backward



Left

Right

Right Joystick



Ascend



Descend



Turn Left

Turn Right

Note

△ To access the Joystick Mode, please go to the "XAG One" App - "Remote Controller Details" - "Joystick Settings".

How to Use

Install Phone Holder

- ① Insert the phone holder into the slot;
- ② Rotate the knob clockwise to tighten the holder.

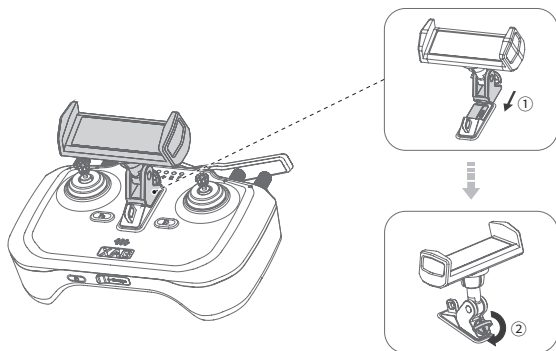

Charge

Connect the Type-C end to the charging port of the remote controller and the USB-A end to the charger.

While charging with the fast charger, the power indicator emits flashing green and the buzzer beeps. The power indicator will turn solid green when the remote controller is fully charged (the remote controller will automatically power off if it's not connected to the aircraft).

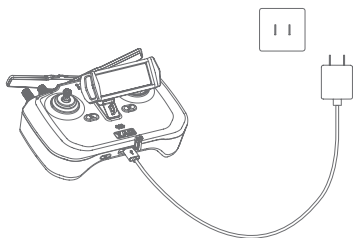

Note







⚠ When the remote controller is on, slow charging only ensures it works at a certain battery percentage. To achieve a full charge, please power off the remote controller.

ON/OFF

ON: Press and hold the power button until 6 indicators flash simultaneously. Then release the power button and long press it again until you hear a prompt indicating that it is powered on successfully.

OFF: Press and hold the power button until 6 indicators flash simultaneously. Then release the power button and long press it again until all 6 indicators are off indicating that it is powered off successfully.

Warning

-  You must charge it with the charging device provided by XAG. Otherwise, you shall be held liable for any product failure or damage arising therefrom.
 -  This product is designed for XAG's products only and there is a strong possibility that this device is incompatible with non-XAG products. Any loss or legal liability arising from such incompatibility shall be borne by you.
 -  Keep the remote controller away from water while it is being charged or in use as it is not waterproof. You shall be responsible for any product failure or damage caused by the device's exposure to water.
 -  The remote controller has a single LTE antenna and is designed for applications that do not require fast data transfer rates.
 -  There is already a SIM card in the SIM1 card slot as the ARC3 leaves the factory. Please do NOT remove this SIM card, or the remote controller might not work properly.
 -  As required by the service provider, an eSIM card (embedded SIM card) may have been inserted in the SIM2 card slot as the remote controller leaves the factory. If you find the SIM2 card slot sealed, do NOT take the seal off or insert other SIM cards or foreign objects. Otherwise, you will be held responsible for any damage caused to the remote controller arising therefrom.
-

Unfold Antennas

Spread out the antennas and adjust them to the suitable positions. Rotate the antennas clockwise to adjust the direction.

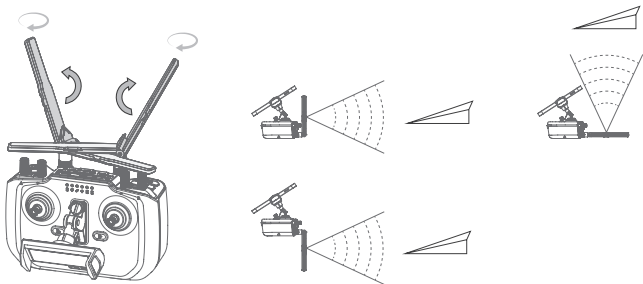

Note

- △ Users can adjust the antenna direction to get the strongest signal when piloting the aircraft with the remote controller as the signal strengths vary according to the antennas' positions.
- △ The signal between the remote controller and the aircraft is affected by factors such as antenna positions, antenna tightness, obstacles and Wi-Fi signal interference. When the signal becomes weak, it is necessary to adjust the antennas or fly the aircraft in a place free of obstacles or Wi-Fi signal interference.

Start Motors

Before a flight, push both the joystick and the throttle as below to start motors. If you fail to push the throttle within 3 seconds after releasing them, the motors will stop automatically.

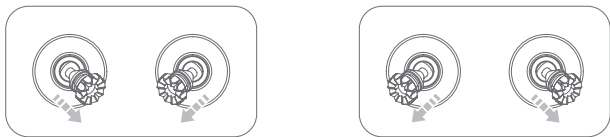

Warning

- △ Do NOT push the joystick and the throttle to start motors when the aircraft is flying because it will cause the aircraft to crash due to the stopping motors.

Stop Motors

After the aircraft lands, pull the throttle to the lowest position, hold it for 1 second and the motors stop.

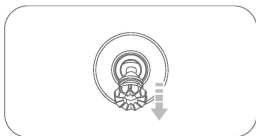



Hover & Return

When the aircraft is in "Autonomous Flight", short press the Stop button to hover it.

When the aircraft is in "Autonomous Flight" or "Manual Operation Mode", long press the Stop button and Fn button to have it return.

Add a Remote Controller

When using the remote controller for the first time, users can follow the steps below to add the remote controller using the phone.

1. Open "XAG One" App, tap  on the upper right corner on "Field" page and select "Add a Device" (or tap on "Me" - "Device" - "  " to add a device).
2. Scan the QR code of the remote controller, or enter the serial number of the remote controller to add.
3. Set the remote controller to Add Mode by following the steps on App page.
4. Set the device name and tap on "OK".

After adding the remote controller, you can use it to start field mapping.

Link Remote Controller

When using the remote controller to operate the aircraft, you need to link an added remote controller. Users can follow the steps below to link the remote controller.

1. Open "XAG One" App, tap on "Me" and then "Device" to select the remote controller to be linked.
2. Tap on "Link the aircraft".
3. Select the aircraft to be linked and tap on "Link".

After the aircraft and the remote controller are linked, you can use the remote controller to fly the aircraft, start flight mapping, etc.

Remote Controller Mapping

Remote controller mapping includes RTK mapping and flight mapping, which will be introduced below.

RTK Mapping

1. Open the USB-C cover on the top of the remote controller, insert RTK module, and then raise the remote controller in the left hand with the RTK module upward and take the phone in the right hand to the field that needs point adding.
2. Open "XAG One" App. On the "Field" page, tap on ⊕ in the upper right corner and select "Create a Field". Select 📶 in the bottom right corner to select the remote controller for mapping.
3. Long press Fn button to enter mapping mode (the buzzer emits two beeps, and the fourth indicator 📶 turns solid green). Hold the remote controller and move to the boundary of the field to be marked. Short press "L1" button to mark the boundary points of the field. After marking all the points, tap on the starting point, and the system will automatically generate a field.
4. Select "Obstacle" / "Non-operating Area". Hold the remote controller and walk around the obstacles/non-operating areas. Short press "L1" button (short press "L2" button to undo the point) to mark the boundary points of obstacles or non-operating areas.
5. After mapping the operating area, tap on "OK" in the upper right corner (or long press "L1" button).
6. Complete field information and tap on "Complete" to save the field.

Note

- ⚠ During RTK mapping, please keep the space above and around RTK module free of obstacles to avoid failed mapping caused by poor signals.

Flight Mapping

1. Open "XAG One" App. On the "Field" page, tap on ⊕ in the upper right corner and select "Create Fields". Select 🛩 in the bottom right corner to select the aircraft for mapping.
 2. Start the aircraft and remotely control it to make it fly over the field that needs point adding. Tap PSL perspective on the phone screen to switch to downward PSL perspective. Short press "L1" button to mark boundary points of the field. Continue to remotely control the aircraft to make it fly to other boundary points and mark. After marking all the points, tap on "Auto Closing" on the App, and the system will automatically generate a field.
 3. Select "Obstacle" or "Non-operating Area". Remotely control the aircraft to make it fly around the obstacles/non-operating areas. Short press "L1" button (short press "L2" button to undo the point) to mark the boundary points of obstacles or non-operating areas.
 4. After mapping the operating area, tap on "OK" in the upper right corner.
 5. Complete field information and tap on "Complete" to save the field.
 6. Remotely control the aircraft to make it fly to the safe area and land, or long press Stop and Fn buttons to make it return.
-

Auxiliary Flight

Auxiliary flight is used to keep the aircraft on course when the flying aircraft is controlled by the remote controller. When auxiliary flight is enabled, the system will automatically adjust and correct the flight route if the aircraft is likely to be off course so as to make the aircraft fly steadily on the current route.

1. Open "XAG One" App, tap on "Me" and then "Device" to enter device list.
2. Tap on "Remote Controller" to enter device details. Select "Parameter Settings" to set manual flight speed, flight height, spraying parameters, etc.
3. Start the aircraft and make it fly to the operating field. Long press "L1" button to generate a route and enter auxiliary flight route (push the joysticks or short press pause button to exit auxiliary flight mode), then push the joystick forward to fly the aircraft on the standard route.
4. In auxiliary flight mode, users can refer to "Basic Operations" on page 3 for other operations of auxiliary flight.

Firmware Update



Before using the device, if the main screen prompts "New Firmware Available", be sure to update the firmware to the latest version.

1. Open the "XAG One" App and tap on "New Firmware Available" to get to the firmware update screen.
2. Tap on "Download and Update". After the update is done, tap on "Complete" to return to the firmware update screen, and check if the firmware is up to date. If not, please try again until the update is completed.

Networking Mode

In the absence of 4G networks, you may connect and link the remote controller to/with the aircraft through networking so as to pilot the aircraft with flexibility without internet access. You may follow the steps below.

Networking

1. When the aircraft is turned on, press and hold the power button of the Smart Battery until the arm lights show flashing yellow. By this time the aircraft goes into networking mode.
2. Turn on the remote controller, after the wireless communication indicator  goes off, press and hold the power button of the remote controller for 10 seconds until the wireless communication indicator  turns flashing yellow. By this time the remote controller goes into networking mode.
3. After the wireless communication indicator  on the remote controller shows flashing green, the remote controller will restart automatically. With a beep from the buzzer, the remote controller is connected to the aircraft.

When the networking is completed, refer to page 9 for the linkage of the remote controller, and pilot the aircraft for aerial mapping with the remote controller.

Joystick Calibration

If the remote controller is not used for an extended period of time, or when you fly the aircraft with the remote controller, and notice that the aircraft will fly toward a certain direction once you release the joysticks or if the function light turns solid red, you will need to calibrate the joysticks. Please follow the steps below to calibrate the joysticks manually or complete the calibration through "Joystick Calibration" under "Remote Controller Details" in the "XAG One" App.

How to Calibrate

1. Move both the left and right joysticks to the far left and at the same time long press button Fn. You will hear a beep from the buzzer with six indicators turning solid yellow, and now the remote controller is in calibration mode.



2. Release both joysticks and button Fn. The six indicators will remain solid yellow, and the remote controller will check the calibration automatically.

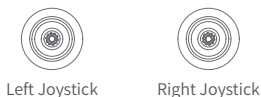

3. Wait until all six indicators turn slow flashing yellow, and move both joysticks to the far end in four directions (forward, backward, left and right) simultaneously.



4. Short press the Stop button, and you will hear a beep from the buzzer, with all six indicators getting back to normal. The calibration is now completed.



Specifications

Model	M3ARC3AH
Dimensions	170×135×65 mm
Operating Frequency	SRRC: 2.4000 GHz to 2.4835 GHz; 5.725 GHz to 5.850 GHz
Effective Isotropic Radiated Power (EIRP)	2.4 GHz SRRC : ≤ 20 dBm 5.8 GHz SRRC : ≤ 33 dBm
2G Operating Frequency	CE: GSM 900: 880 – 915 MHz, 925 – 960 MHz; DCS 1800: 1710 – 1785, 1805 – 1880 MHz FCC: GSM850; PCS1900 ANATEL: GSM850、GSM900、GSM1800、GSM 1900
2G Maximum transmit power	Class 4 (33dBm ±2dB)for EGSM900, Class 1 (30 dBm ±2 dB) for DCS1800
3G Operating Frequency	CE: WCDMA Band I: 1920 – 1980 MHz, 2210 – 2170 MHz; WCDMA Band VIII: 880 – 915 MHz, 925 – 960 MHz FCC: WCDMA B4; WCDMA B2 KCC: WCDMA B1 ANATEL: WCDMA B1、WCDMA B2、WCDMA B5、WCDMA B8 MIC: WCDMA B1、WCDMA B5、WCDMA B6、WCDMA B8、WCDMA B19
3G Maximum transmit power	Class 3 (24dBm +1/-3dB) for WCDMA bands
4G Operating Frequency	CE: Band1、Band3、Band7、Band8、Band20、Band28、Band38、Band40 FCC: Band2、Band4、Band5、Band7、Band12、Band13、Band25、Band26、Band38、Band41 KCC: Band1、Band3、Band5、Band7、Band8 ANATEL: Band1、Band3、Band5、Band8、Band25、Band26、Band28、Band39、Band40、Band41 MIC: Band1、Band3、Band5、Band8、Band18、Band19、Band26、Band28、Band41
4G Maximum transmit power	Class 3 (23dBm ±2dB) for LTE-TDD bands
Operating System Supported	Android, iOS
Built-in Battery Capacity	4932mAh, 7.38V
Ambient Temperature for Charging	0°C to 45°C
Ambient Temperature for Operating ^[1]	-20°C to 55°C

Ambient Temperature for Storage	-20°C to 25°C (three months to one year) -20°C to 45°C (one month to three months) -20°C to 55°C (less than a month)
Max. Effective Signal Range ^[2]	1000 m
Charging Voltage/Current	5 V / 2 A, 9 V / 1.5 A, 12 V / 1.5 A
Warning Buzzer	Supported
RTK Frequency Band	GPS: L1/L2 BDS: B1/B2 Galileo: E1/E5b GLONASS: L1/L2
Positioning Accuracy (Good RTK Signal)	Horizontal: < 5 cm+1 ppm (RMS) Vertical: < 7.5 cm+1 ppm (RMS)

[1]: The remote controller's battery performance might be affected when the ambient temperature for operating is lower than -5°C .

[2]: This is the result of tests conducted outdoors (with no obstruction or interference) in line with FCC standards. It is not necessarily the actual effective range and is for reference only.

Disclaimer

1. Please read this Disclaimer carefully before using this product, as it has much to do with both operational safety and your legitimate rights and interests. You shall be deemed to have read, known, understood, agreed to and accepted all the terms and conditions and information stated herein upon use of the product.
 2. Not being a toy, this product is not suitable for those who are under 18 years old, those who have no or limited capacity for civil conduct, or those with mobility impairments. Please keep children away from this product and be particularly cautious with children present.
 3. You pledge to use the product within the bounds of the law for legitimate purposes only and agree to all the content contained in this User Manual.
 4. Please install and use the product under the instructions in this User Manual. Do NOT modify or disassemble this product on your own, or you shall solely assume the liability arising from such modification or disassembly, both financially and legally.
 5. To the maximum extent permitted by law, XAG shall not be liable for any loss caused by your use of this product outside this Disclaimer or the instructions in this User Manual. Furthermore, XAG shall not be liable for any indirect, consequential, punitive, accidental, special or exemplary damage, including any loss incurred as a result of your purchase, use, or inability to use the product, even if you have been advised of the possibility of such loss.
 6. Please install, use, transport, and maintain the product under the instructions in this User Manual. Do NOT modify or disassemble this product on your own as any malfunction or damage resulting from your improper use, modification or disassembly will not be covered by the warranty, and you shall solely assume the liability arising therefrom, both financially and legally.
 7. You understand that in the use of any products, accidents may occur as a result of single or combined factors, including but not limited to improper operation, surroundings and communication networks. You understand that the aforesaid accidents are reasonable and acceptable in the use of the product, and that XAG shall not be held accountable for such accidents.
 8. To the maximum extent permitted by law, under any circumstances, the liability or compensation amount from XAG to you for all damage, losses and litigation arising therefrom will not exceed the amount that you paid to XAG for purchasing the product.
 9. On any account, purchaser or user shall comply with the laws and regulations of the country and region where the product is used. XAG shall assume no liability arising from the violation of relevant laws and regulations by the purchaser or user.
 10. As exclusion clauses may be prohibited by law in some countries, your rights in different countries may vary. However, this does not imply that part or all of the terms contained in this Disclaimer are necessarily invalid.
 11. To the extent permitted by law, XAG reserves the right for final explanation and revision of the terms and conditions stated hereinabove. XAG also has the right to update, modify or terminate these terms and conditions via its official website, User Manual, online App, etc., without prior notice.
-

Warning

User is required to read through the User Manual and get familiar with the operation of this product before use. Otherwise, improper operation may cause injury to user or others, or cause damage to the product and property loss. Safety awareness is of great importance during operation. Do NOT use any components that are not provided or suggested by XAG. Please install and use the product by strictly following XAG's instructions.
